

RSI53-20
53' TRAILER
"OSTRANGER"

RSI53-20

53' TRAILER

AIR BRAKE ASSEMBLY

2008

700M060

AIR BRAKE CHAMBER CONNECTOR ASSEMBLY

SERVICE

7000203 (2)
PARKER
159F-10-6

EMERGENCY

7000864 (2)
PARKER
159F-8-6

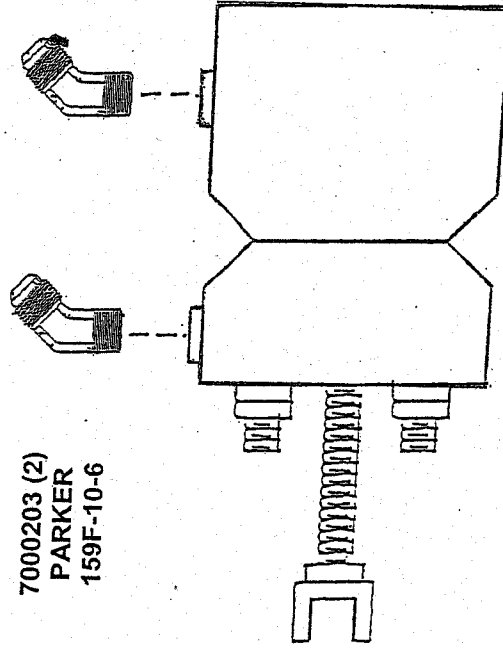

2200199 (4)
AIR BRAKE CHAMBER
HALDEX 30/30 166101

AIR BRAKE HOSE COMPONENTS

7000001
PARKER
16826-8-8



7000116
PARKER
293-8



7000173
PARKER
10126-6-8

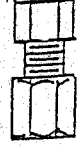

7000001
PARKER
16826-8-8



7000116
PARKER
293-8



7000142
PARKER
68NTA-6-6

EMERGENCY

SERVICE

7000002
PARKER
16826-10-10



7000117
PARKER
293-10



7000002
PARKER
16826-10-10

AIR BRAKE VALVE MOUNTING PLATE ASSEMBLY

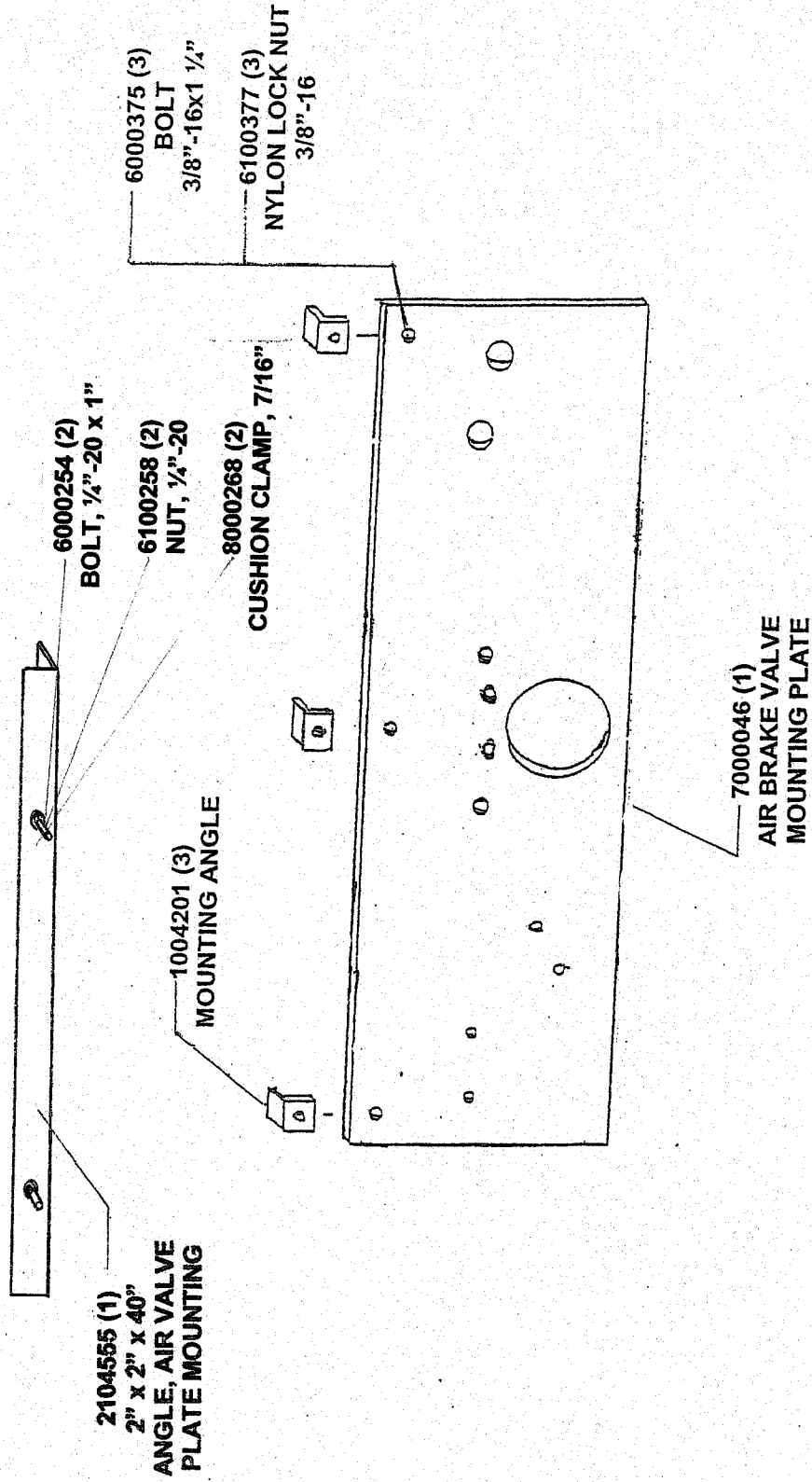

AIR FILTER ASSEMBLY

7000110 (1)
2550 SEALCO
AIR FILTER

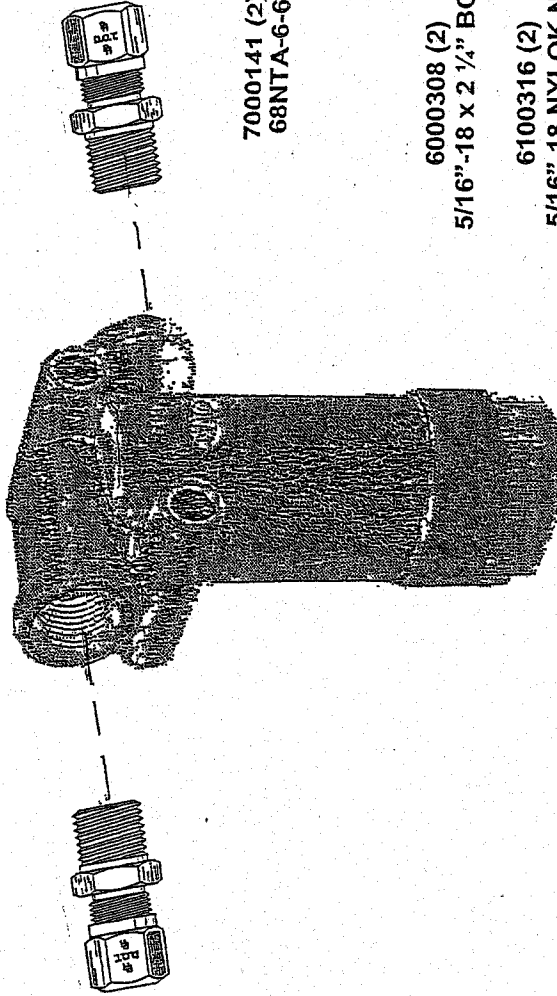

7000141 (2)
68NTA-6-6

6000308 (2)
5/16\"-18 x 2 1/4\" BOLT

6100316 (2)
5/16\"-18 NYLOK NUT

AIR TANK ASSEMBLY

700N104
AIR TANK FASTENER ASSEMBLY

6000375 (4)
BOLT - GRADE 8
3/8" -16 x 1 1/2"

6100381 (4)
LOCKNUT - GRADE 8
3/8" -16

6200376 (8)
FLAT WASHER
3/8" USS

7000851 (1)
3/8" NPT
PIPE PLUG

DRAIN VALVE ASSEMBLY
700N016

7000165 (1)
DRAIN VALVE - 60"
HEBCO / SLOAN 401047

7000901 (1)
RING, 1"
BARON 8894T50

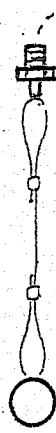

7000143 (1)
PARKER
68NTA-8-6



7000931 (1)
STREET ELBOW
3/8" x 3/8"

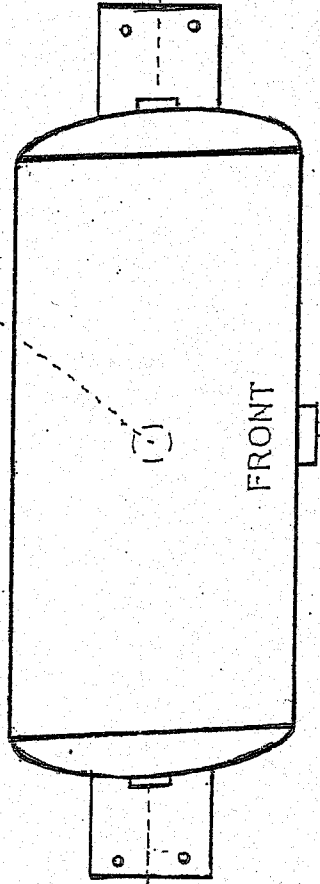

7000102 (1)
AIR TANK 12"
HOOSIER HT-1211

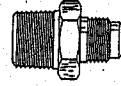

7000170 (1)
PARKER
48F-10-12

700N056

AIR TANK MOUNTING BRACKET ASSEMBLY

2201657 (2)
GUSSET, AIR TANK
MOUNTING BRACKET

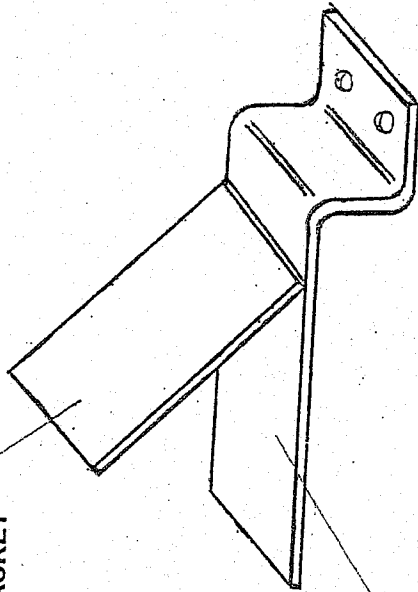

2204501 (2)
BRACKET, AIR
TANK MOUNTING

210N764
210N769

ANCHOR CONNECTOR ASSEMBLY – SLIDER HOSES

7000172 (2)
207ACBH-8

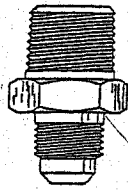
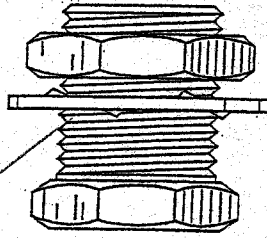

7000151 (2)
48F-8-8

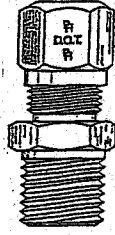

7000144 (2)
68NTA-6-8



2104528 (1)
MOUNTING PLATE

6300115 (3)
POP RIVET, 8-6

8000268 (2)
7/16" CUSHION CLAMP



6300126 (2)
POP RIVET, 6-6

CHANNEL, SLIDER HOSE HANGER ASSEMBLY

LOCATED ON SUSPENSION BOX



6100256 (3)
1/4"-20 S.S. KEP NUT



8000268 (4)
7/16" CUSHION CLAMP

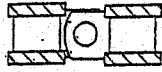

7/16"

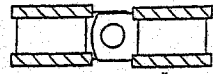

8000261 (4)
3/4" CUSHION CLAMP

6000254 (3)
BOLT
1/4"-20 x 1"

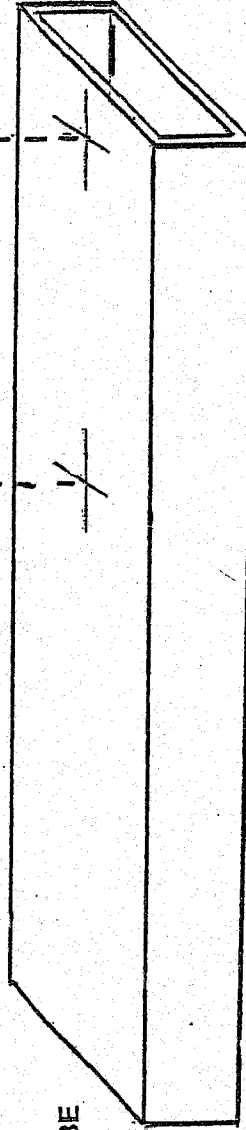

7700533 (1)
MOUNTING TUBE

FRONT

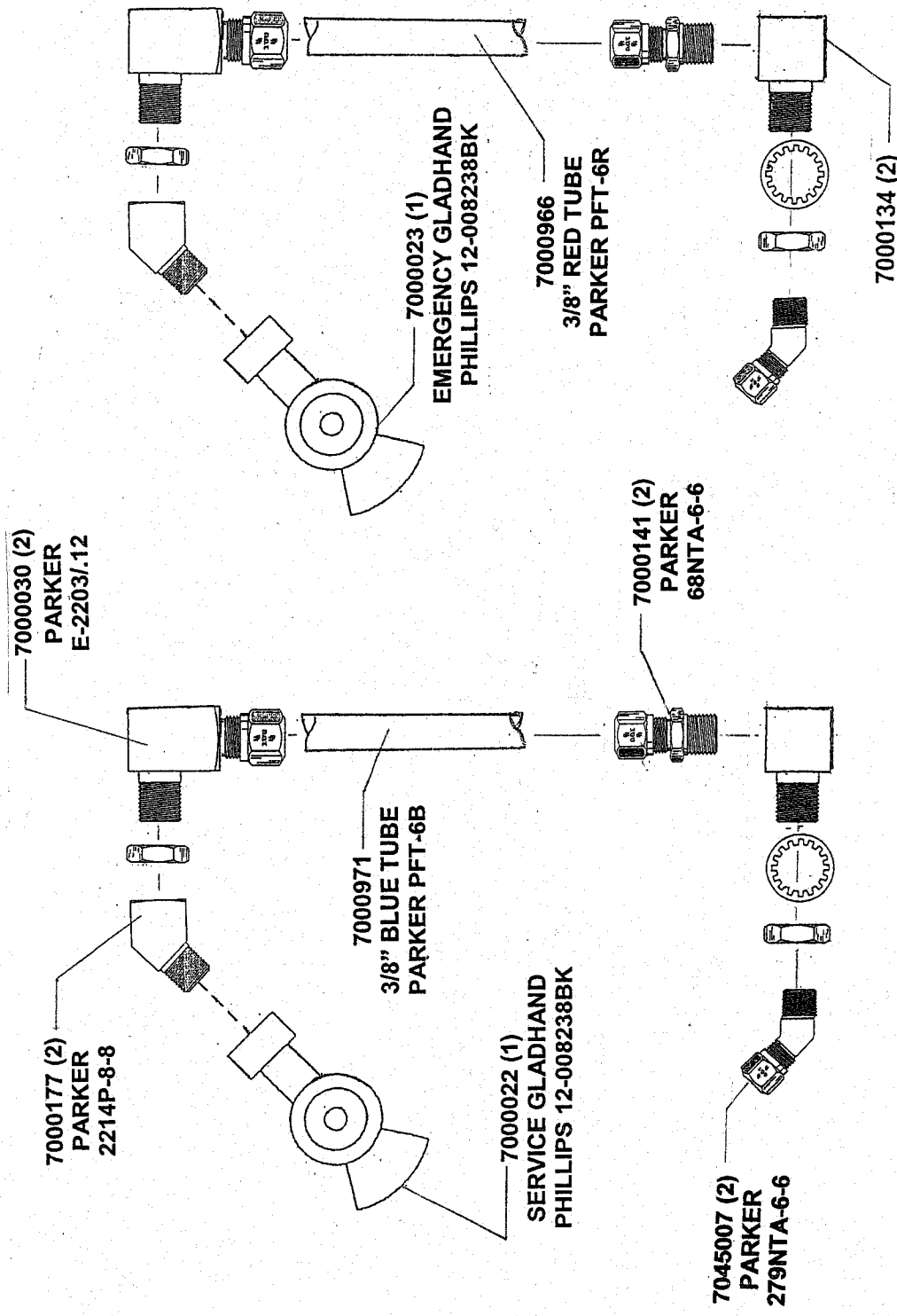

7000030 (2)
PARKER
E-2203/12

7000177 (2)
PARKER
2214P-8-8

7000971
3/8" BLUE TUBE
PARKER PFT-6B

7000022 (1)
SERVICE GLADHAND
PHILLIPS 12-008238BK

7000023 (1)
EMERGENCY GLADHAND
PHILLIPS 12-008238BK

7000966
3/8" RED TUBE
PARKER PFT-6R

7000141 (2)
PARKER
68NTA-6-6

7045007 (2)
PARKER
279NTA-6-6

7000134 (2)
ANCHOR COUPLING
TRAMEC 50016 / 3/8"

GLADHAND ASSEMBLY -- FLUSH MOUNT FORWARD WALL

HOSE ADAPTOR ASSEMBLY

7700533 (1)
1" x 2" x 24"
HOSE HANGER TUBE

REF: 210N102

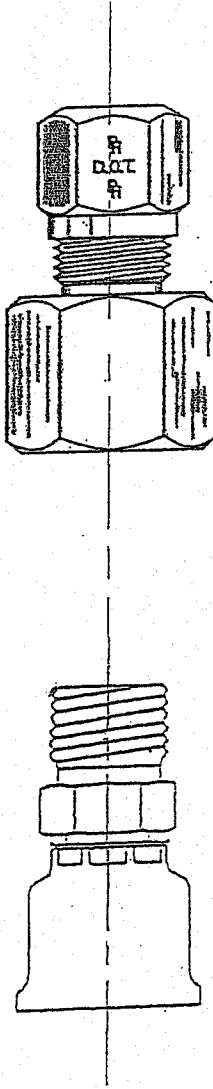

7000173 (2)
10126-6-8

7000142 (2)
68NTA-6-6

LOCATIONS - VALVE PLATE & AIR TANK

2104555 (1)
2" x 2" x 40"

AIR PLATE MOUNTING ANGLE

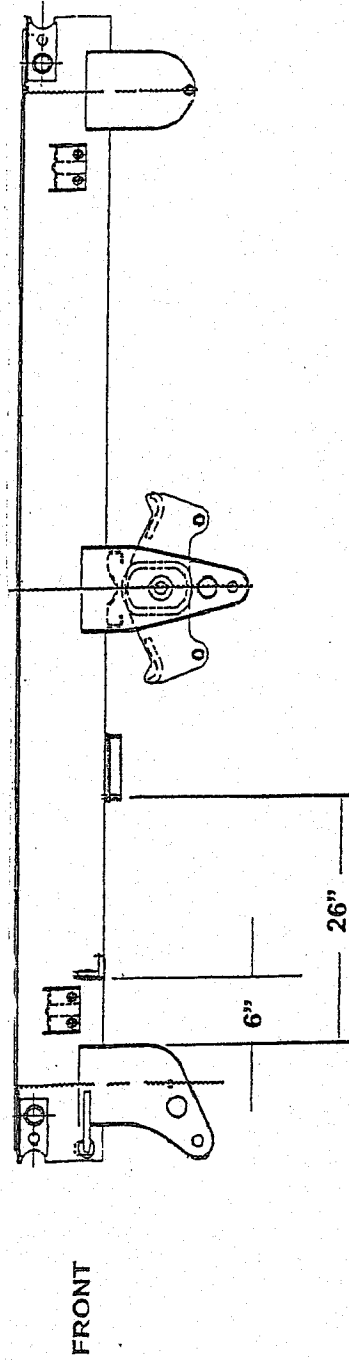

2204501 (2)
AIR TANK MOUNTING BRACKET

MAIN HARNESS AND TUBING CLAMP ASSEMBLY

6300126 (1)
POP RIVET, 6-6



8000261 (2)
3/4" CUSHION CLAMP

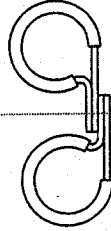

LOCATED AT ROADSIDE,
REAR OF UPPER COUPLER

RELAY VALVE ASSEMBLY

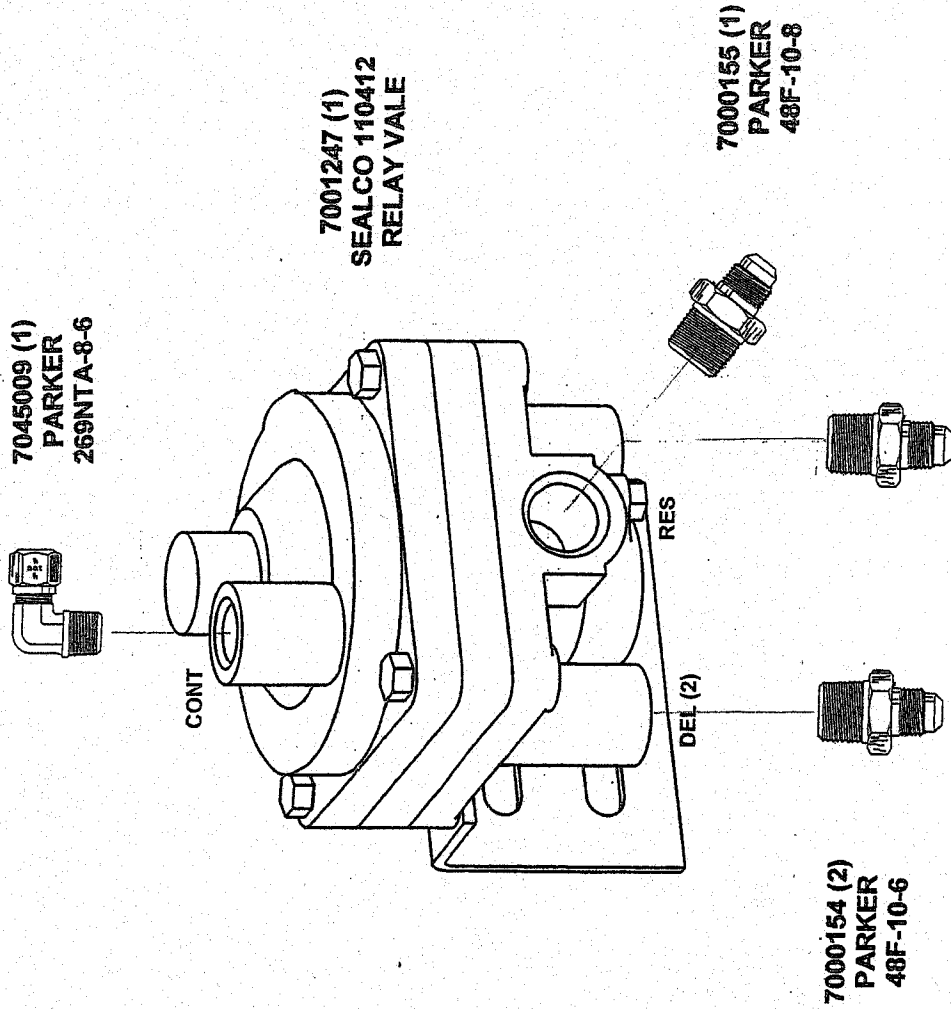

6000376 (2)
BOLT
3/8"-16 x 1"

6100377 (2)
LOCKNUT
3/8"-16

6200378 (2)
FLAT WASHER
3/8" SAE

7001247 (1)
SEALCO 110412
RELAY VALE

7045009 (1)
PARKER
269NTA-8-6

7000155 (1)
PARKER
48F-10-8

7000154 (2)
PARKER
48F-10-6

SPRING BRAKE VALVE ASSEMBLY

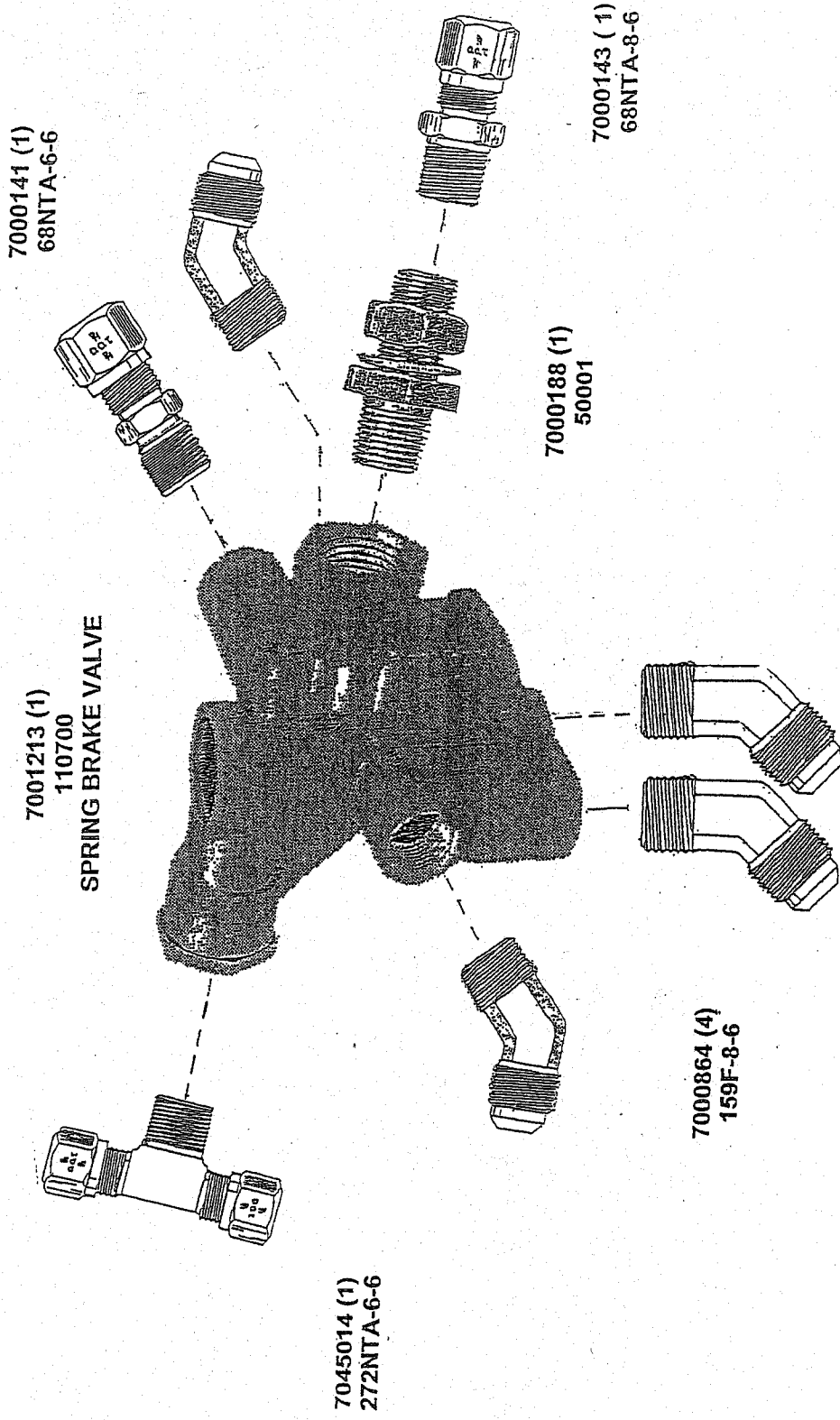

RSI 53'20 TRAILER - 700N237

V.3 5-19-08

WITH SPRING SUSPENSION AND RELAY VALVE & SHORT CAMSHAFT AXLES

AIR BRAKE HOSE LIST

RSI #	QTY	SIZE	TUBE / HOSE	CONN. 7000002	CONN. 7000001	CONN. 7000173
7000966	40' 0"	3/8"	RED			
7000968	3-0'	1/2"	BLACK			
7000971	42' 0"	3/8"	BLUE			
7100017	1	14"	7000116	# 8	2	
SPRING BRAKE VALVE TO FRONT AIR CHAMBER R/S						
7100037	2	96"	7000116	# 8	1	1
SLIDER HOSES						
7100038	1	75"	7000116	# 8	2	
SPRING BRAKE VALVE TO REAR AIR CHAMBER R/S						
7100034	1	79"	7000116	# 8	2	
SPRING BRAKE VALVE TO REAR AIR CHAMBER C/S						
7100058	1	22"	7000116	# 8	2	
SPRING BRAKE VALVE TO FRONT AIR CHAMBER C/S						
7100019	1	78"	7000117	#10	2	
RELAY VALVE TO REAR AIR CHAMBER C/S						
7100010	1	17"	7000117	#10	2	
ABS VALVE TO RELAY VALVE						
7100029	1	86"	7000117	#10	2	
RELAY VALVE TO REAR AIR CHAMBER R/S						
7100040	1	14"	7000117	#10	2	
ABS VALVE TO AIR TANK						
7100059	2	19"	7000117	#10	2	
ABS VALVE TO FRONT AIR CHAMBER R/S & C/S						

SPRING TENDER ASSEMBLY

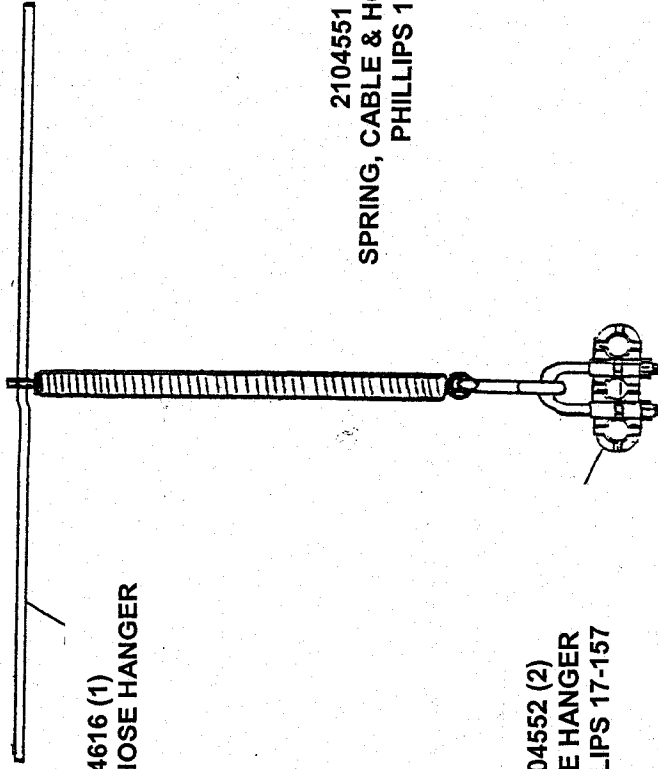

2104616 (1)
ROD, AIR HOSE HANGER

2104551 (2)
SPRING, CABLE & HOSE SUPPORT
PHILLIPS 17-116

2104552 (2)
HOSE HANGER
PHILLIPS 17-157

WABCO ABS VALVE ASSEMBLY

- 7001218 (2)
SENSOR W/ SOCKET
MERITOR 441-032-8080
- 7001223 (2)
SENSOR WIRE 72"
MERITOR 449-713-0180
- 7001224 (2)
SENSOR CLIP
MERITOR 899-759-8154
- 7001230 (1)
POWER CABLE
MERITOR S 4493260600

7001229 (1)
MERITOR ABS VALVE
S4005001010

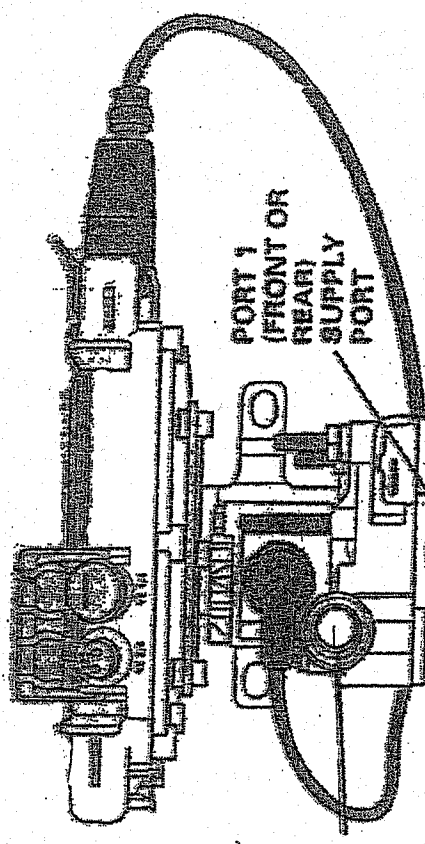

7045008 (1)
PARKER
269NTA-6-6

7045009 (1)
PARKER
269NTA-8-6

6000375 (2)
BOLT
3/8"-16 x 1 1/4"

6100377 (2)
LOCKNUT
3/8"-16

6200378 (4)
FLAT WASHER
3/8" SAE

7000154 (2)
PARKER
48F-10-6

7000851 (1)
3/8" PIPE PLUG

7000170 (2)
PARKER
48F-10-12

BUMPER ASSEMBLY (210N101) **RSI53-20 "OSTRANGER"**

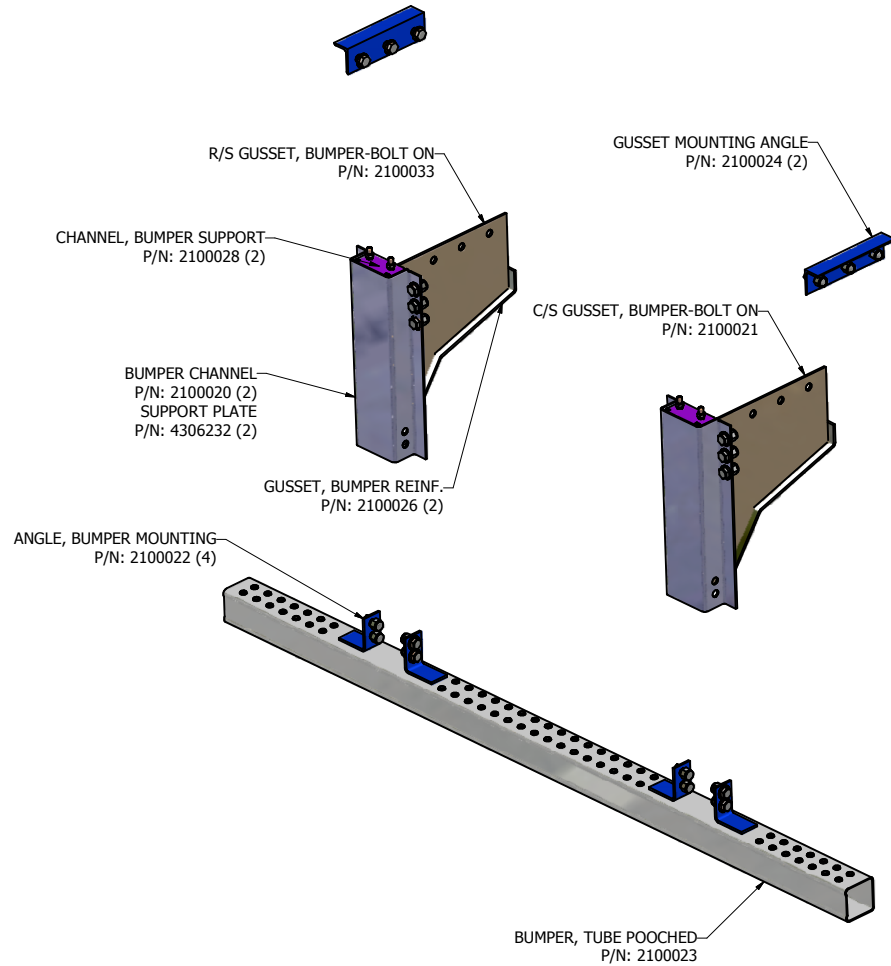

FASTENERS:

BOLT, 1/2-20x1-1/2"
P/N: 6000501 (4)

BOLT, 3/4-16x2" GR-5
P/N: 6000750 (6)

BOLT, 3/4-16x1-1/2" GR-5
P/N: 6000751 (20)

LOCK NUT, 1/2-20 GR-5
P/N: 6100501 (4)

NUT, 3/4-16 GR-5
P/N: 6100751 (26)

WASHER, FLAT 1/2"
P/N: 6200503 (4)

WASHER, FLAT 3/4"
P/N: 6200751 (26)

MUDFLAPS ASSEMBLY (240N216)

RSI53-20 "OSTRANGER"

MUDFLAP BACKING PLATE
P/N: 2400214 (2)

MUDFLAP MOUNTING ANGLE
P/N: 2400216 (1)

MUDFLAP GT-2430 S
P/N: 2400211 (2)

FASTENERS:

SCREW, HEX CAP 3/8-16 X 1-1/2"
P/N: 6000378 (8)

LOCKNUT, HEX STOVER 3/8-16
P/N: 6100382 (8)

WASHER, FLAT 3/8 USS PLTD
P/N: 6200376 (8)

